

Concave and convex washers DIN 6319, edition 10/01

Item description/product images



Description

Material:

Hardened steel or stainless steel.
Form G in tempered, heat-treated steel at HV 390 ±40.

Surface finish:

Case-hardened.
Stainless steel not hardened, natural finish.

Note:

Use form G for rough surfaces, along holes or notches.

Statements on load capacity are not valid for stainless steel versions.

Drawings

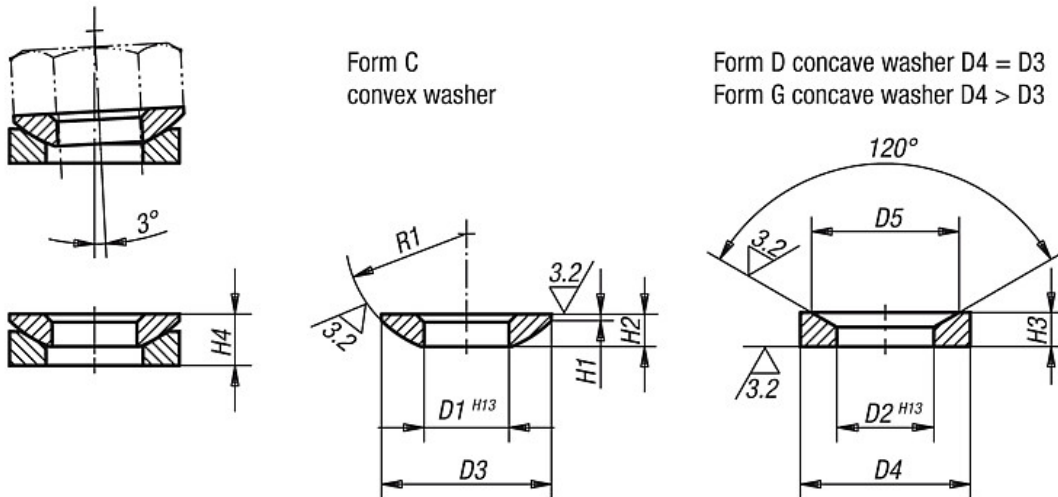

Overview of items

Order No. steel	Order No. stainless steel	Form	D1	D2	D3	D4	D5	H1	H2	H3	H4	R1	for screw Ø	Load capacity max. kN (static load only)	Approx. weight g
K0729.105	-	C	5,25	-	10,5	-	-	0,4	2	-	-	7,5	5	-	0,8
K0729.106	K0729.0106	C	6,4	-	12	-	-	0,7	2,3	-	-	9	6	9/-	0,9
K0729.108	K0729.0108	C	8,4	-	17	-	-	0,6	3,2	-	-	12	8	17/-	2,5
K0729.110	K0729.0110	C	10,5	-	21	-	-	0,8	4	-	-	15	10	26/-	5,0
K0729.112	K0729.0112	C	13	-	24	-	-	1,1	4,6	-	-	17	12	38/-	7,3
K0729.114	-	C	15	-	28	-	-	1,2	5	-	-	22	14	53	11,4
K0729.116	K0729.0116	C	17	-	30	-	-	1,3	5,3	-	-	22	16	73/-	12,7
K0729.120	K0729.0120	C	21	-	36	-	-	2	6,3	-	-	27	20	117/-	22,0
K0729.124	K0729.0124	C	25	-	44	-	-	2,4	8,2	-	-	32	24	168/-	43,0
K0729.130	K0729.0130	C	31	-	56	-	-	3,6	11,2	-	-	41	30	269/-	110,0
K0729.136	K0729.0136	C	37	-	68	-	-	4,6	14	-	-	50	36	394/-	190,0
K0729.142	K0729.0142	C	43	-	78	-	-	6,5	17	-	-	58	42	542/-	305,0
K0729.148	K0729.0148	C	50	-	92	-	-	8	21	-	-	67	48	714/-	540,0
K0729.156	-	C	58	-	103	-	-	9,5	23	-	-	79	56	-	760,0
K0729.164	-	C	66	-	120	-	-	12	27	-	-	93	64	-	1220,0
K0729.205	-	D	-	6	-	10,5	9,25	-	-	2,1	3,1	-	5	-	1,5
K0729.206	K0729.0206	D	-	7,1	-	12	11	-	-	2,8	4	-	6	9/-	1,3
K0729.208	K0729.0208	D	-	9,6	-	17	14,5	-	-	3,5	5,6	-	8	17/-	3,5

Concave and convex washers DIN 6319, edition 10/01

Overview of items

Order No. steel	Order No. stainless steel	Form	D1	D2	D3	D4	D5	H1	H2	H3	H4 with concave washer	R1	for screw Ø	Load capacity max. kN (static load only)	Approx. weight g
K0729.210	K0729.0210	D	-	12	-	21	18,5	-	-	4,2	6,3	-	10	26/-	6,7
K0729.212	K0729.0212	D	-	14,2	-	24	20	-	-	5	8	-	12	38/-	10,0
K0729.214	-	D	-	16,5	-	28	24,8	-	-	5,6	8,2	-	14	53	14,4
K0729.216	K0729.0216	D	-	19	-	30	26	-	-	6,2	9,3	-	16	73/-	18,0
K0729.220	K0729.0220	D	-	23,2	-	36	31	-	-	7,5	11,6	-	20	117/-	31,0
K0729.224	K0729.0224	D	-	28	-	44	37	-	-	9,5	15	-	24	168/-	61,0
K0729.230	K0729.0230	D	-	35	-	56	49	-	-	12	18,9	-	30	269/-	130,0
K0729.236	K0729.0236	D	-	42	-	68	60	-	-	15	23,3	-	36	394/-	230,0
K0729.242	K0729.0242	D	-	49	-	78	70	-	-	18	28,3	-	42	542/-	360,0
K0729.248	K0729.0248	D	-	56	-	92	82	-	-	22	35,2	-	48	714/-	640,0
K0729.256	-	D	-	65	-	103	92	-	-	25	39,7	-	56	-	900,0
K0729.264	-	D	-	75	-	120	110	-	-	30	46,5	-	64	-	1430,0
K0729.305	-	G	-	6	-	15	9,25	-	-	2,5	3,5	-	5	-	3,5
K0729.306	K0729.0306	G	-	7,1	-	17	11	-	-	4	5,2	-	6	9/-	5,3
K0729.308	K0729.0308	G	-	9,6	-	24	14,5	-	-	5	6,8	-	8	17/-	13,5
K0729.310	K0729.0310	G	-	12	-	30	18,5	-	-	5	7,1	-	10	26/-	21,0
K0729.312	K0729.0312	G	-	14,2	-	36	20	-	-	6	9	-	12	38/-	38,0
K0729.314	-	G	-	16,5	-	40	24,8	-	-	6	8,6	-	14	53	47,0
K0729.316	K0729.0316	G	-	19	-	44	26	-	-	7	10,1	-	16	73/-	64,0
K0729.320	K0729.0320	G	-	23,2	-	50	31	-	-	8	12	-	20	117/-	92,0
K0729.324	K0729.0324	G	-	28	-	60	37	-	-	10	15,5	-	24	168/-	165,0
K0729.330	K0729.0330	G	-	35	-	68	49	-	-	12	18,7	-	30	269/-	238,0
K0729.336	-	G	-	42	-	80	60	-	-	12	20,3	-	36	394	350,0