

Side clamps

Item description/product images

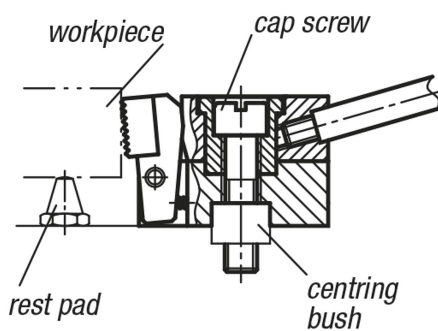
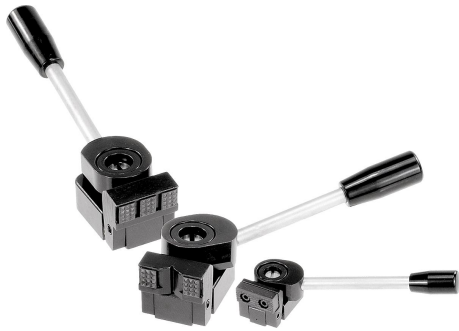

Description

Material:

Steel.

Version:

Case-hardened and black oxidised.

Note:

This is a quick-action side clamp where workpieces are clamped by rotating a cam wheel which exerts pressure on the swivel jaw, simultaneously producing a positive down force.

Using the centring bush (see diagram), the side clamp can be mounted and positioned on a modular grid system.

The versions K0035.006010, K0035.006015, K0035.006030 and K0035.006035 have 2 round carbide inserts.

Clamping force:

K0035.006... = 3800 N

K0035.010... = 7200 N

Drawings

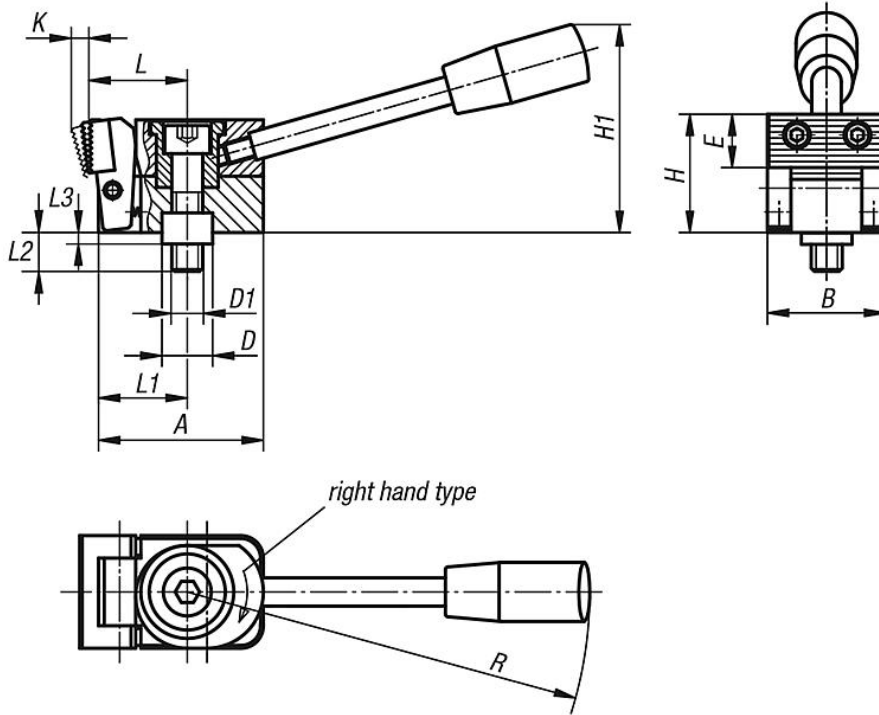

Form A
steel jaw
serrated

Form B
jaw with 2 round
carbide inserts

Form C
jaw with 2 round
carbide inserts
and central prism

Form D
POM jaw
serrated

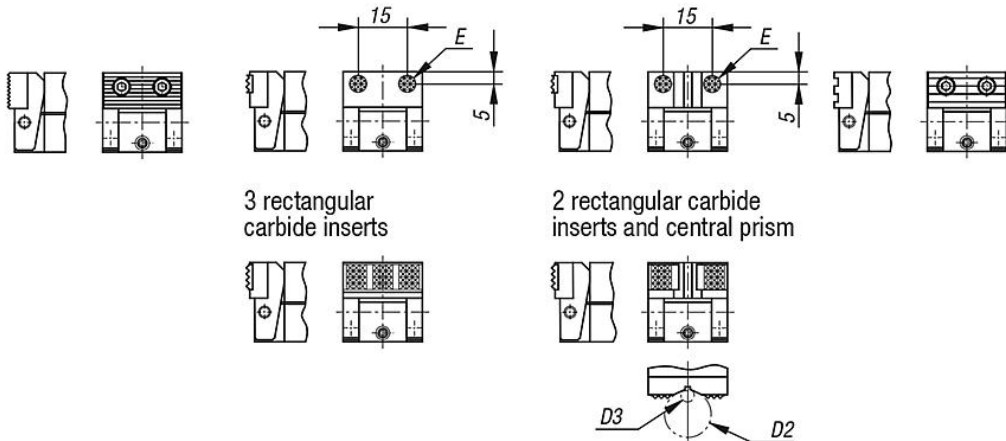

Overview of items

Side clamps

Order No.	Form	Version 1	A	B	D	D1	D2 max.	D3 min.	E	H	H1	K	L	L1	L2	L3	R	F=retaining force N
K0035.006005	A	right	38,5	25	12	M6	-	-	11	25	45	4	22	20	17	4	110	3800
K0035.010005	A	right	58,5	40	18	M10	-	-	18	40	74	6	35	31,5	27	6	143	7200
K0035.006025	A	left	38,5	25	12	M6	-	-	11	25	45	4	22	20	17	4	110	3800
K0035.010025	A	left	58,5	40	18	M10	-	-	18	40	74	6	35	31,5	27	6	143	7200
K0035.006010	B	right	38,5	25	12	M6	-	-	∅8	24	45	3,5	22	20	17	4	110	3800

Side clamps

Overview of items

Order No.	Form	Version 1	A	B	D	D1	D2 max.	D3 min.	E	H	H1	K	L	L1	L2	L3	R	F=retaining force N
K0035.010010	B	right	58,5	40	18	M10	-	-	12,7	39	74	5,5	37	31,5	27	6	143	7200
K0035.006030	B	left	38,5	25	12	M6	-	-	∅8	24	45	3,5	22	20	17	4	110	3800
K0035.010030	B	left	58,5	40	18	M10	-	-	12,7	39	74	5,5	37	31,5	27	6	143	7200
K0035.006015	C	right	38,5	25	12	M6	9,5	2,5	∅8	24	45	3,5	22	20	17	4	110	3800
K0035.010015	C	right	58,5	40	18	M10	27	4,5	12,7	39	74	5,5	37	31,5	27	6	143	7200
K0035.006035	C	left	38,5	25	12	M6	9,5	2,5	∅8	24	45	3,5	22	20	17	4	110	3800
K0035.010035	C	left	58,5	40	18	M10	27	4,5	12,7	39	74	5,5	37	31,5	27	6	143	7200
K0035.006020	D	right	38,5	25	12	M6	-	-	11	25	45	4,5	22	20	17	4	110	3800
K0035.010020	D	right	58,5	40	18	M10	-	-	18	40	74	7	34,5	31,5	27	6	143	7200
K0035.006040	D	left	38,5	25	12	M6	-	-	11	25	45	4,5	22	20	17	4	110	3800
K0035.010040	D	left	58,5	40	18	M10	-	-	18	40	74	7	34,5	31,5	27	6	143	7200