

Ground hook clamps form A/B/C

Item description/product images

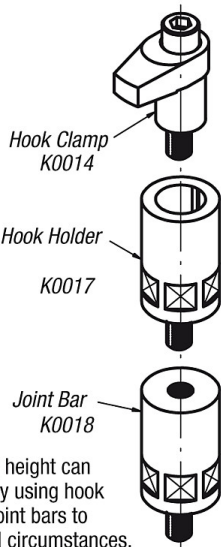

The clamping height can be adjusted by using hook holders and joint bars to suit individual circumstances.

Description

Material:

Tempered steel, heat-treated

Surface finish:

Black oxide finish, shaft diameter ground

Note:

The stated clamping forces and tightening torques are valid within the stated clamping range (H5).

Drawings

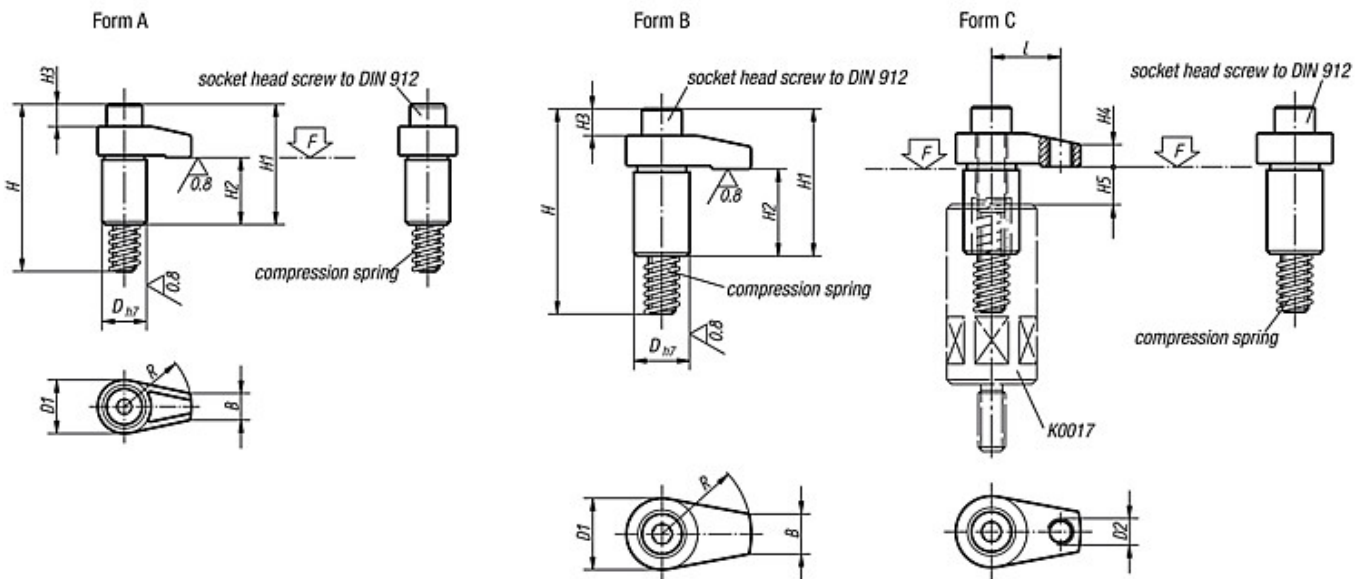

Ground hook clamps form A/B/C

Overview of items

Order No.	Form	D	D1	D2	H	H1	H2	H3	H4	H5 max. clamping range	B	L	R	Socket head screw DIN 912	Tightening torque max. Nm	F max. kN	Approx. weight kg
K0014.208020	B	18	22	-	58	37	23	2	7	10	10	-	20	M8x50	37,2	13,6	0,090
K0014.208025	B	18	22	-	58	37	23	2	7	10	10	-	25	M8x50	32,3	10,9	0,095
K0014.208030	B	18	22	-	58	37	23	2	7	10	10	-	30	M8x50	29,4	9	0,105
K0014.110030	A	20	24	-	75	54	30	9	10	12	12	-	30	M10x65	37,2	13	0,162
K0014.110040	A	20	24	-	75	54	30	9	10	12	12	-	40	M10x65	31,4	9,8	0,173
K0014.212040	B	25	32	-	92	66	39	11	12	15	18	-	40	M12x80	58,8	17,5	0,300
K0014.312140	C	25	32	M12	92	66	39	11	10	15	18	31	40	M12x80	58,8	22,6	0,295
K0014.312150	C	25	32	M12	92	68	39	11	13	15	18	38	50	M12x80	49	18,5	0,353
K0014.212050	B	25	32	-	92	68	39	11	12	15	18	-	50	M12x80	49	14	0,365
K0014.212060	B	25	32	-	92	68	39	11	12	15	18	-	60	M12x80	45,1	11,6	0,395
K0014.312160	C	25	32	M12	92	68	39	11	13	15	18	46	60	M12x80	45,1	15,2	0,390
K0014.216040	B	32	36	-	101	75	39	15	15	15	22	-	40	M16x85	166,6	37,9	0,505
K0014.216050	B	32	36	-	101	75	39	15	15	15	22	-	50	M16x85	147	30,4	0,575
K0014.316150	C	32	36	M12	101	75	39	15	16	15	22	38	50	M16x85	147	38	0,558
K0014.216060	B	32	36	-	101	75	39	15	15	15	22	-	60	M16x85	127,4	25,2	0,619
K0014.316160	C	32	36	M12	101	75	39	15	16	15	22	46	60	M16x85	127,4	33	0,600