

# Straight crank handles similar DIN 469

## Item description/product images



### Description

#### Material:

Malleable or ductile cast iron crank arm.

#### Surface finish:

Blasted.

## Drawings

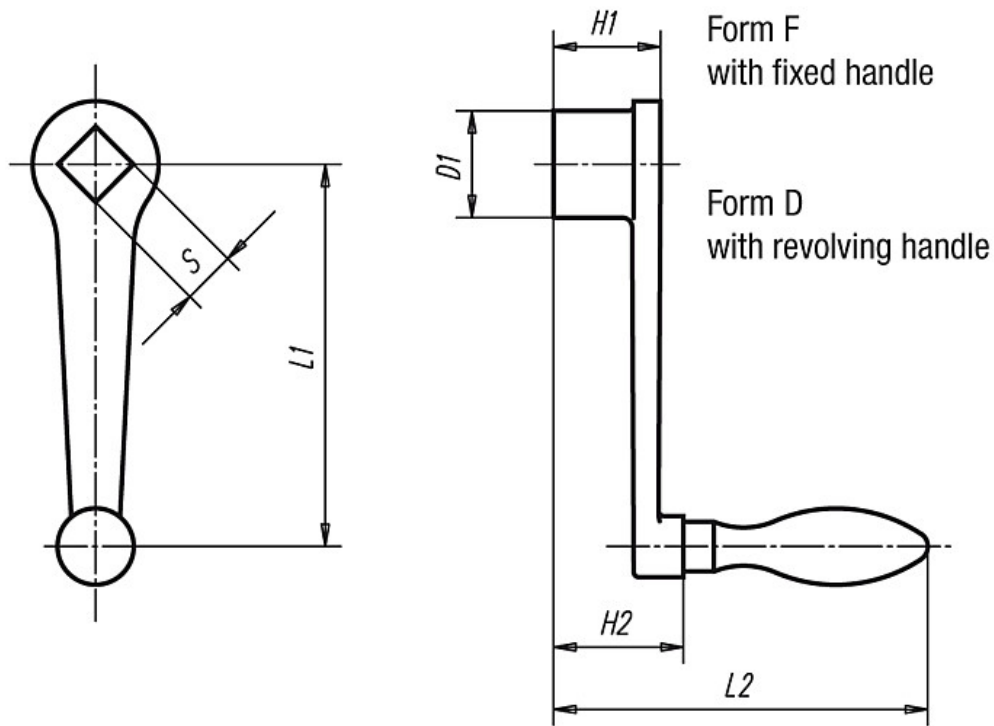

## Overview of items

Order No.	Form	L1	L2	S	D1	H1	H2	Diameter handle	Approx. weight kg
K0685.106X10	F	63	80	10 +0,2	20	20	28	16	0,135
K0685.108X10	F	80	98	10 +0,2	24	24	33	20	0,250
K0685.108X12	F	80	98	12 +0,2	24	24	33	20	0,250
K0685.110X12	F	100	102	12 +0,2	28	28	37	20	0,330
K0685.110X14	F	100	102	14 +0,3	28	28	37	20	0,330
K0685.112X14	F	125	120	14 +0,3	34	34	40	25	0,550
K0685.112X17	F	125	120	17 +0,3	34	34	40	25	0,550
K0685.116X17	F	160	131	17 +0,3	37	38	48	25	0,720
K0685.116X19	F	160	131	19 +0,3	37	38	48	25	0,720
K0685.120X19	F	200	158	19 +0,3	40	44	53	32	1,140
K0685.120X22	F	200	158	22 +0,3	40	44	53	32	1,140
K0685.206X10	D	63	80	10 +0,2	20	20	28	16	0,135
K0685.208X10	D	80	98	10 +0,2	24	24	33	20	0,250

## Straight crank handles similar DIN 469

### Overview of items

Order No.	Form	L1	L2	S	D1	H1	H2	Diameter handle	Approx. weight kg
K0685.208X12	D	80	98	12 +0,2	24	24	33	20	0,250
K0685.210X12	D	100	102	12 +0,2	28	28	37	20	0,330
K0685.210X14	D	100	102	14 +0,3	28	28	37	20	0,330
K0685.212X14	D	125	120	14 +0,3	34	34	40	25	0,550
K0685.212X17	D	125	120	17 +0,3	34	34	40	25	0,550
K0685.216X17	D	160	131	17 +0,3	37	38	48	25	0,720
K0685.216X19	D	160	131	19 +0,3	37	38	48	25	0,720
K0685.220X19	D	200	158	19 +0,3	40	44	53	32	1,140
K0685.220X22	D	200	158	22 +0,3	40	44	53	32	1,140