

Clamping plates for quarter-turn clamp locks

Item description/product images

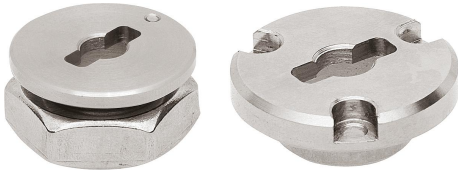

Description

Material:

Housing steel or stainless steel.

Nut stainless steel.

Version:

Housing nickel-plated or bright.

Nut bright.

Note:

M2 or M3 mounting screws are supplied.

Form A mounting option for plate thickness 6 to 10 mm.

Form B mounting option for plate thickness over 10 mm.

Drawing reference:

- 1) plate
- 2) quarter-turn clamp lock
- 3) locating pin
- 4) nut

Clamping plates for quarter-turn clamp locks

Drawings

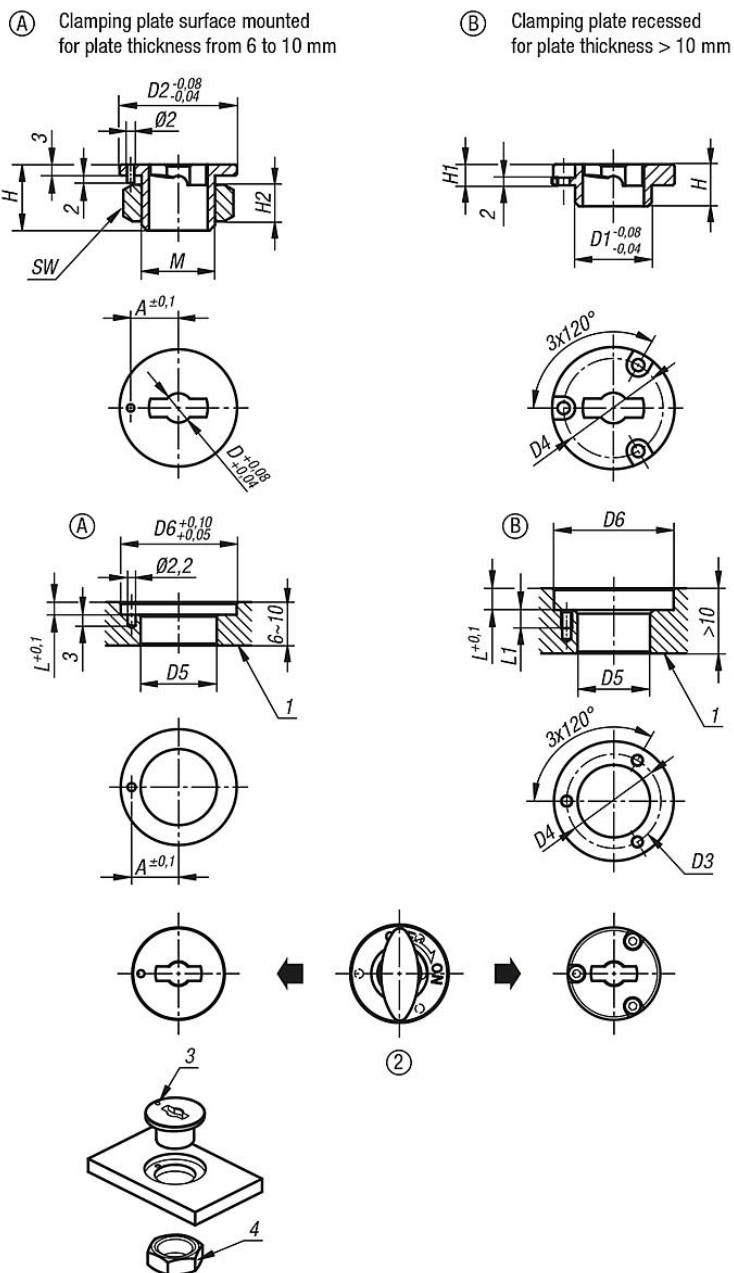

Overview of items

Clamping plates for quarter-turn clamp locks

Order No.	Form	Version 1	Main material	D	D1	D2	D4	A	M	H2	SW	H	H1	D3 for screw to DIN 912	D5	D6	L	L1
K1062.50	A	superimposed	steel	5	-	25	-	10,5	M14X1,5	8	22	16	-	-	15	25	3,5	-
K1062.80	A	superimposed	steel	8	-	32	-	13	M20X1,5	10	30	18	-	-	21	32	3,5	-
K1062.150	A	superimposed	stainless steel	5	-	25	-	10,5	M14X1,5	8	22	16	-	-	15	25	3,5	-
K1062.180	A	superimposed	stainless steel	8	-	32	-	13	M20X1,5	10	30	18	-	-	21	32	3,5	-
K1062.501	B	countersunk	steel	5	14	25	21	-	-	-	-	9	4,5	M2	14	26	5	4
K1062.801	B	countersunk	steel	8	20	32	26	-	-	-	-	11	5,5	M3	20	33	6	5
K1062.1501	B	countersunk	stainless steel	5	14	25	21	-	-	-	-	9	4,5	M2	14	26	5	4
K1062.1801	B	countersunk	stainless steel	8	20	32	26	-	-	-	-	11	5,5	M3	20	33	6	5

