

## Wedge clamps

### Item description/product images



### Description

#### Material:

Channel aluminium profile.  
Wedge hardened steel.

#### Version:

Channel anodized.  
Wedge black oxidised.

#### Note:

Two workpieces can be held simultaneously with the wedge clamp. They are ideal for clamping round or rectangular pieces. The compact design allows space-saving series clamping.

#### Drawing reference:

In clamped position dimension B1 max. given in the table should be achieved.

### Drawings

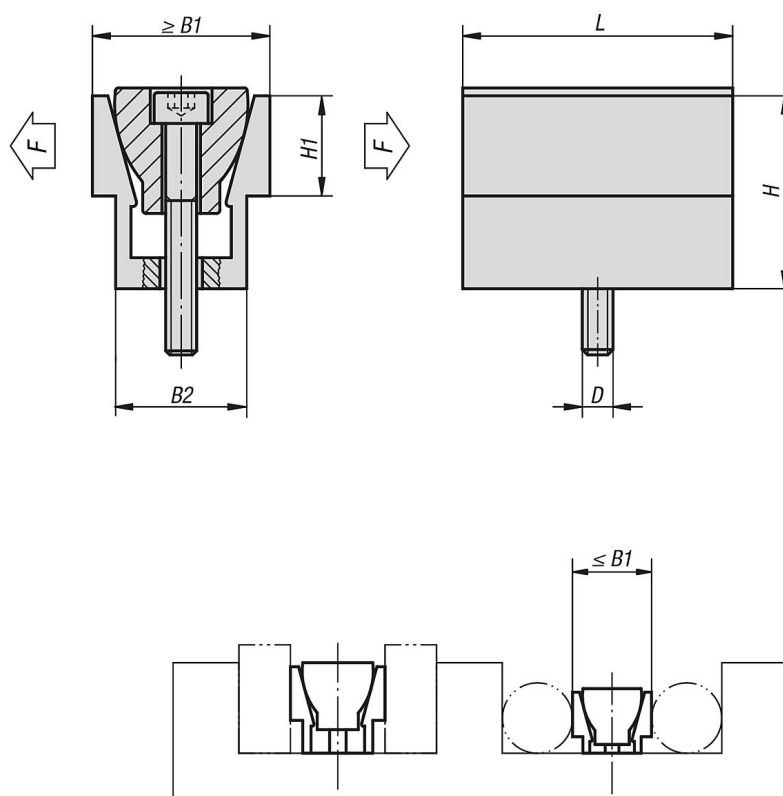

### Overview of items

#### Wedge clamps

Order No.	D	L	B1 min. - max.	B2	H	H1	F kN	Tightening torque max. Nm
K0037.04	M4	15,9	12,3 - 13,1	10,4	12,7	5,6	2,2	3,4
K0037.06	M6	23,8	18,6 - 19,9	16,1	19	9,5	6,7	14,3

## Wedge clamps

### Overview of items

Order No.	D	L	B1 min. - max.	B2	H	H1	F kN	Tightening torque max. Nm
K0037.08	M8	31,7	24,8 - 26,6	20,8	25,4	12,7	8,9	14,5
K0037.12	M12	47,6	37,3 - 39,7	30,8	38,1	19	15,6	38,4
K0037.16	M16	63,5	49,7 - 52,8	41,2	50,8	25,4	26,7	74,6